

CT41 CHIP MULTILAYER CERAMIC CAPACITORS

Middle & High Voltage Capacitors 200V~5000V

INTRODUCTION

Middle and high voltage series MLCC is designed by a special internal electrode pattern, which can reduce voltage concentrations by distributing voltage gradients throughout the entire capacitor. This special design also affords increased capacitance values in a given case size and voltage rating.

Capacitors with X7R dielectrics are not intended for AC line filtering applications. Capacitors may require protective surface coating to prevent external arcing.

FEATURES

High voltage in a given case size.

High stability and reliability.

APPLICATIONS

Snubbers in high frequency power converters.

High voltage coupling/DC blocking.

DC-DC converters.

Back-lighting inverters

HOW TO ORDER

<u>0805</u>	<u>T</u>	<u>104</u>	<u>M</u>	<u>251</u>	<u>C</u>	<u>R</u>
<u>Size</u>	<u>Dielectric</u>	<u>Capacitance</u>	<u>Tolerance</u>	<u>Rated voltage</u>	<u>Termination</u>	<u>Packaging style</u>
Inch (mm)	N=NPO	Two significant	N=+/-0.03pF	Two significant	C=Cu/Ni/Sn	R = T&R
0201 (0603)	B=X7R	digits followed by	A=+/-0.05pF	digits followed by		
0402 (1005)	C=X7S	no. of zeros. And	B=+/-0.1pF	no. of zeros. And		
0603 (1608)	F=Y5V	R is in place of	C=+/-0.25pF	R is in place of		
0805 (2012)	S=X6S	decimal point.	D=+/-0.5pF	decimal point.	201=200 VDC	
1206 (3216)	X=X5R	eg.:	F=+/-1%	251=250 VDC		
1210 (3225)	T=X7T	0R5=0.5pF	G=+/-2%	501=500 VDC		
1808 (4520)		1R0=1.0pF	J=+/-5%	631=630 VDC		
1812 (4532)		104=10x10 ⁴	K=+/-10%	102=1000 VDC		
1825 (4563)		=100nF	M=+/-20%	202= 2000 VDC		
2211 (5728)			Z=-20%~+80%	302= 3000 VDC		
2220 (5750)				402= 4000 VDC		
2225 (5763)						

The Outlines and External Dimensions of Capacitors

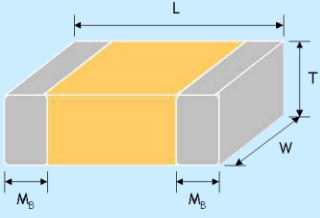
Outline	Size Inch (mm)	L (mm)	W (mm)	T (mm)/Symbol	Soldering Method *	M _B (mm)	
	01R5 (0402)	0.4±0.02	0.2±0.02	0.2±0.02	V	R	0.10±0.03
	0201 (0603)	0.6±0.03	0.3±0.03	0.3±0.03	L	R	0.15±0.05
		0.6±0.05 ^{#2}	0.3±0.05 ^{#2}	0.3±0.05 ^{#2}			0.15±0.1/-0.05
		0.6±0.09 ^{#3}	0.3±0.09 ^{#3}	0.3±0.09 ^{#3}			
	0402 (1005)	1.00±0.05	0.50±0.05	0.50±0.05	N	R	0.25 +0.05/-0.10
		1.00±0.20	0.50±0.20	0.50+0.02/-0.05	Q	R	
				0.5±0.20	E	R	
	0603 (1608)	1.60+0.15/-0.10	0.80+0.15/-0.10	0.80±0.07	S	R / W	0.40±0.15
				0.50±0.10	H	R / W	
				0.80+0.15/-0.10	X	R / W	
				1.60±0.20 ^{#1}	0.80±0.20 ^{#1}	0.8±0.20 ^{#1}	
	0805 (2012)	2.00±0.15	1.25±0.10	0.50±0.10	H	R / W	0.50±0.20
				0.60±0.10	A	R / W	
				0.80±0.10	B	R / W	
				1.25±0.10	D	R	
				0.85±0.10	T	R / W	
	1206 (3216)	3.20±0.15	1.60±0.15	1.25±0.20	I	R	0.60±0.20 (0.5±0.25) ^{***}
				0.80±0.10	B	R / W	
				0.95±0.10	C	R	
				1.25±0.10	D	R	
1.15±0.15				J	R		
1.60±0.20				G	R		
0.85±0.10				T	R / W		
3.20+0.30/-0.10	1.60+0.30/-0.10	1.60+0.30/-0.10	P	R			
1210 (3225)	3.20±0.30	2.50±0.20	0.95±0.10	C	R	0.75±0.25	
			0.85±0.10	T	R		
			1.25±0.10	D	R		
			1.60±0.20	G	R		
			2.00±0.20	K	R		
			2.50±0.30	M	R		
3.20±0.60 ^{#4}	2.50±0.50 ^{#4}	2.50±0.50 ^{#4}					
1808 (4520)	4.50±0.40 (4.5+0.5/-0.3) ^{**}	2.03±0.25	1.25±0.10	D	R	0.75±0.25 (0.5±0.25) ^{***}	
			1.40±0.15	F	R		
			1.60±0.20	G	R		
			2.00±0.20	K	R		
1812 (4532)	4.50±0.40 (4.5+0.5/-0.3) ^{**}	3.20±0.30	1.25±0.10	D	R	0.75±0.25 (0.5±0.25) ^{***}	
			1.60±0.20	G	R		
			2.00±0.20	K	R		
			2.50±0.30	M	R		
			2.80±0.30	U	R		
1825 (4563)	4.60±0.50	6.30±0.40	1.60±0.20 (G) 2.00±0.20 (K)		R	≧ 0.26	
2211 (5728)	5.70±0.50	2.80±0.30			R	≧ 0.30	
2220 (5750)	5.70±0.50	5.00±0.40	2.50±0.30 (M)		R	≧ 0.30	
2225 (5763)	5.70±0.50	6.30±0.40	2.80±0.30 (U)		R	≧ 0.30	

* R = Reflow soldering process ; W = Wave soldering process.

** For 1808_200V ~3kV, 1812_200V~3kV

*** For 1206_1000V ~3kV, 1808_200V ~3kV, 1812_200V~3kV

#1 : For 0603/Cap ≥ 10μF or 0603(≤6.3V)/Cap ≥ 4.7μF or 0603(>10V)/Cap > 1μF products.

#2 : For 0201/Cap ≥ 0.68μF products.

#3 : For 0201/Cap ≥ 1μF products.

#4 : For 1210(100V)/Cap > 1μF or 1210(250V)/Cap > 0.47μF or 1210(400V~630V)/Cap > 0.22μF.

GENERAL ELECTRICAL DATA

Dielectric	NP0	X7R	X7T	Y5V
Size	0603, 0805, 1206, 1210, 1808, 1812, 1825, 2220, 2225		0805, 1206, 1210, 1812	0805, 1206, 1210, 1812
Capacitance	0.5pF to 0.12μF	100pF to 2.2μF	0.01uF to 0.33uF	0.01μF to 0.68μF
Capacitance tolerance	Cap≤5pF: C (±0.25pF) 5pF<Cap<10pF: D (±0.5pF) Cap≥10pF: J (±5%), K (±10%)	K (±10%), M (±20%)	K (±10%), M (±20%)	Z (-20/+80%)
Rated voltage (WVDC)	200V to 4000V	200V to 5000V	250V to 630V	200V, 250V
DF/ Q	Cap<30pF: Q≥400+20C Cap≥30pF: Q≥1000	≤2.5%	≤1.0%	≤5%
Insulation resistance at Ur	Ur=200~630V: ≥10GΩ or RxC≥100Ω·F whichever is smaller Ur=1000~3000V: ≥10GΩ			
Dielectric strength	200~300V: ≥2 x WVDC 400V~450V: ≥1.2 x WVDC 500~999V: ≥1.5 x WVDC 1000~3000V: ≥1.2 x WVDC 4000: ≥1.1 x WVDC			
Operating temperature	-55 to +125°C			-25 to +85°C
Capacitance characteristic	±30ppm	±15%	+22/-33%	+30/-80%
Termination	Ni/Sn (lead-free termination)			

CAPACITANCE RANGE

Y5V Dielectric 200V to 250V

DIELECTRIC		Y5V							
SIZE		0805		1206		1210		1812	
RATED VOLTAGE (VDC)		200	250	200	250	200	250	200	250
Capacitance	0.010μF (103)	B	B	B	B	C	C	D	D
	0.015μF (153)	B	B	B	B	C	C	D	D
	0.022μF (223)	B	B	B	B	C	C	D	D
	0.033μF (333)	B	B	B	B	C	C	D	D
	0.047μF (473)	B	B	B	B	C	C	D	D
	0.068μF (683)	B	B	B	B	C	C	D	D
	0.10μF (104)			B	B	C	C	D	D
	0.15μF (154)			C	C	C	C	D	D
	0.22μF (224)							D	D
	0.33μF (334)							D	D
0.47μF (474)							D	D	
0.68μF (684)							D	D	

1. The letter in cell is expressed the symbol of product thickness.

CAPACITANCE RANGE

X7T Dielectric 250V to 630V

DIELECTRIC		X7T															
SIZE		0805				1206				1210				1812			
RATED VOLTAGE (VDC)		250	350	450	630	250	350	450	630	250	350	450	630	250	350	450	630
Capacitance	0.010μF (103)		T	T					T								
	0.015μF (153)		T	T					T								
	0.022μF (223)		D	D					J								
	0.033μF (333)	D	D	D					J								
	0.047μF (473)	D	D	D					G								
	0.068μF (683)	D															
	0.10μF (104)	D				P	P						P				
	0.15μF (154)												K				P
	0.22μF (224)					P						K					
0.33μF (334)									K						P		

1. The letter in cell is expressed the symbol of product thickness.

General Information

Constructions

No.	Name	NP0	NPO/X7R/X7T/X5R/Y5V
①	Ceramic material	BaTiO ₃ based	
②	Inner electrode	AgPd alloy	Ni
③	Termination	Inner layer	Ag
④		Middle layer	Ni
⑤		Outer layer	Sn

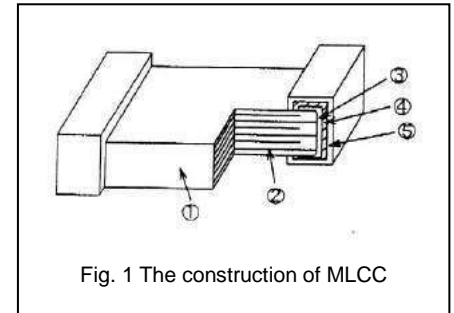

Storage and handling conditions

- (1) To store products at 5 to 40°C ambient temperature and 20 to 70% related humidity conditions.
- (2) The product is recommended to be used within one year after shipment. Check solderability in case of shelf life extension is needed.

Cautions:

- a. The corrosive gas reacts on the terminal electrodes of capacitors, and results in the poor solderability. Do not store the capacitors in the ambience of corrosive gas (e.g., hydrogen sulfide, sulfur dioxide, chlorine, ammonia gas etc.)
- b. In corrosive atmosphere, solderability might be degraded, and silver migration might occur to cause low reliability.
- c. Due to the dewing by rapid humidity change, or the photochemical change of the terminal electrode by direct sunlight, the solderability and electrical performance may deteriorate. Do not store capacitors under direct sunlight or dewing condition. To store products on the shelf and avoid exposure to moisture.

Recommended soldering conditions

The lead-free termination MLCCs are not only to be used on SMT against lead-free solder paste, but also suitable against lead-containing solder paste. If the optimized solder joint is requested, increasing soldering time, temperature and concentration of N₂ within oven are recommended.

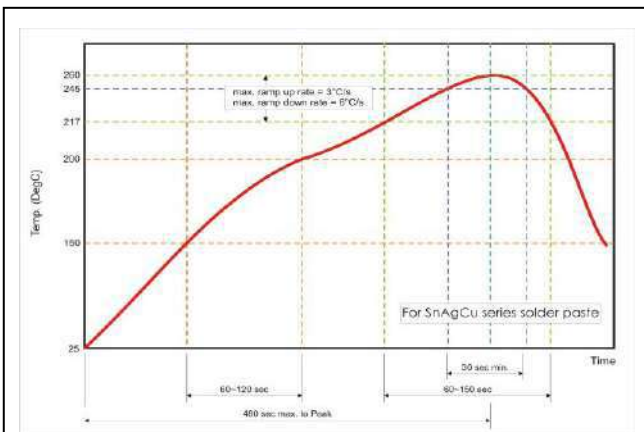

Fig. 2 Recommended reflow soldering profile for SMT process with SnAgCu series solder paste.

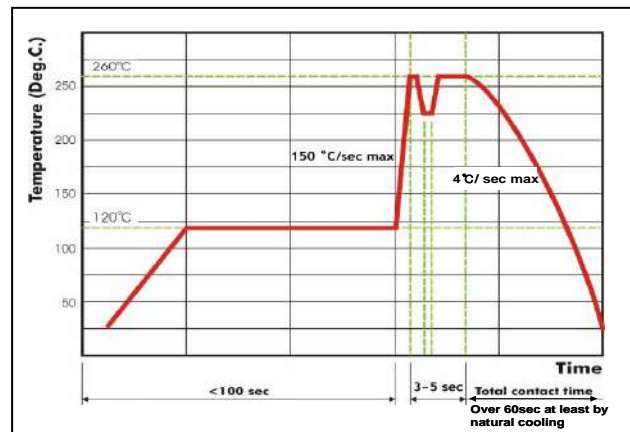

Fig. 3 Recommended wave soldering profile for SMT process with SnAgCu series solder.